



CURVE
by platinum



**PRODUCT
BROCHURE**

THE PLATINUM CURVE STAIRLIFT

Welcome to the Platinum Curve stairlift. A smooth and comfortable twin-rail stairlift, ideal for curved staircases with an ergonomic seat that is fully adjustable to you.

Choosing a stairlift can be an overwhelming decision. However, the freedom offered in helping you return to independent living without having to leave the home you love makes it a great choice, providing you with a better quality of life and peace of mind for you, and your loved ones.



WHY CHOOSE A PLATINUM CURVE STAIRLIFT?



CUSTOM BUILT QUALITY

Every Platinum Curve stairlift is hand-crafted entirely to your home's specification and installed with your individual requirements in mind. The Platinum Curve twin rail is capable of navigating the majority of staircases and excels in narrow staircases and tight turns, maintaining a smooth ride throughout.



COMFORT

The Platinum Curve stairlift comes with an ergonomic seat, adjustable arms, backrest and footplate providing an easy and comfortable journey for users of every size and shape.

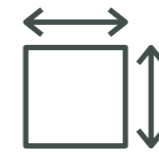

SPACE-SAVING SOLUTIONS

The Platinum Curve comes with space-saving features such as the Ergo Space Seat and Ergo Plus Seat pad. The floor mounted rail, easy foldaway seat, arms and lever activated footplate, leaves your stairs free from obstruction.



SAFETY

Safety is paramount, for your peace of mind. Every stairlift is designed and tested to the highest standards (Machinery Directive 2006/42/EC and EN81/40) before it leaves the manufacturing facility to ensure it fits your staircase exactly, and gives you the confidence in independent living.

GET TO KNOW THE PLATINUM CURVE STAIRLIFT

The Platinum Curve stairlift offers you the ideal combination of function and comfort, letting you enjoy living in the home you love. Its innovative design means it can fit where other stairlifts cannot.

Tailor made for you and your home, there are several options that are configured to you and your comfort at the point of order, and installation. Here, we have detailed these and many other benefits, so you can be confident in your decision that the Curve is the right stairlift for you.

COMFORT

Choices for an easy and comfortable stairlift

- The Ergo Seat pad options are shaped to make sitting on the seat easy for the user, whatever size or shape
- A lever linked footplate means no awkward bending to fold up the footplate
- Powered or manual lever swivel for easy exiting of the seat
- Can accommodate up to 25st (160kg)

Adjustable arms,
backrest and
footplate



Ergonomic
joystick is an
easy to use
function



SAFETY

For you and your loved ones peace of mind

- Easy to use seat belt for your safety
- Our stairlifts are battery powered, so, in the event of a power cut you can still access your home
- Automatic stop feature, if there is an obstacle on your stairs
- Text display for real time information, easily visible on the armrest



Text display



Remote control to call and park your stairlift at the top or bottom of the stairs.

A space-saving shorter rail



SPACE - SAVING SOLUTIONS

A stairlift that works in any home

- The option of the short 90 parking bend rail start saves space
- Foldaway arms, seat and footplate ensuring your stairlift leaves your stairs fully accessible for others



YOUR OPTIONS

The Platinum Curve comes with a choice of key features to make it an accessible chair for everyone to use and to fit seamlessly into your home.



The Ergo Space Backrest can be adjusted to accommodate the user

SEAT ADJUSTMENTS

Power activated or manual seat lever swivel

THE WEIGHT OPTIONS

A choice of weight capacity.



Foot Cover

THE RAIL

Standard, Short 90 wrap, 90 & 180 wraps and Overruns



Standard Start



Short 90 wrap



90 & 180 wraps



Overruns

THE SEAT

Fully adjustable Ergo seat with any combination of Ergo Standard Backrest and Seat pad or Ergo Space Backrest and Ergo Plus Seat pad for your comfort.



Standard Seat pad



The Ergo Plus Seat pad

THE UPHOLSTERY

Colours to suit your home décor.



Ruby Red



Cobalt Blue



Light Grey



Almond Beige

THE PLATINUM CURVE JOURNEY

Six simple steps to help you enjoy your whole home.

1 Call your stairlift using the remote control.



2 Lower the armrests and the seat pad, put the footplate down with the easy to reach side lever. Your stairlift is ready to use. The screen will display 'Platinum', meaning you are ready to go.



3 Your chair will be fully adjusted to your size and shape at installation, so all you need to do is sit comfortably in the chair, engage the seat belt and you are ready.



4 To operate your stairlift, simply use the ergonomic joystick in the armrest and lightly press in the direction you wish to travel.



5 Once you have arrived the powered swivel will turn the chair, and when it finishes, unbuckle and safely step off. If your lift has a manual swivel, use the lever situated under the seat to swivel the seat.

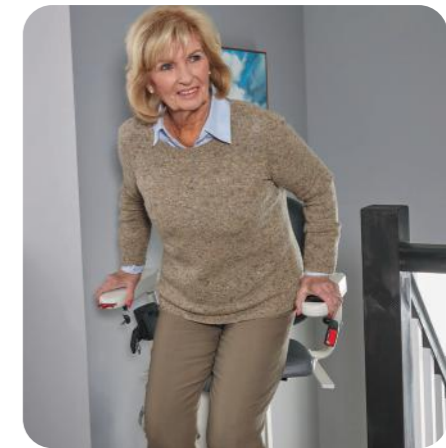

6 On arrival, fold up the arms and seat, and use the footplate lever to fold it away. Once finished using the stairlift, turn the power off by turning the key under the armrest.

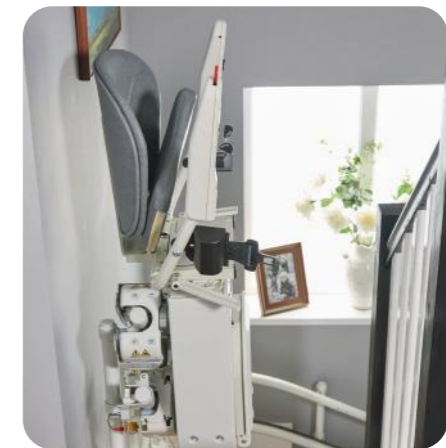

PLATINUM CURVE SPECIFICATION

SPEED:	120mm/s (0.12m/s) Maximum
DRIVE:	350W Rack and Pinion Drive
WEIGHT CAPACITY:	120kg (19St) 160kg (25St)
STAIRCASE INCLINE:	Up to 52°
OPERATION:	Arm mounted Ergo Joystick/Toggle Switch or Infrared or Radio remote call and sends.
CERTIFICATION:	BS EN 81:40 MACHINERY DIRECTIVE 2006/42/EC
RAIL LENGTH:	28m Maximum rail length
SEAT SWIVEL:	Manual swivel seat as standard available with lever linked or powered footplate Powered swivel seat as option available with powered footplate Powered Swivel not available on Heavy Duty model Swivel levers mounted horizontally at both sides of the seat
FOOTPLATE:	Manual lever link on carriage or powered option.
SEAT HEIGHT:	ERGO seat height 484mm
SEAT VARIATIONS:	Fully adjustable Ergo Seat with options of Ergo standard backrest and seat pad or Ergo Space backrest and Ergo Plus seat pad.
SAFETY:	Safety edges on footplate and carriage Over-speed governor Electro-magnetic Motor brake Retractable Reel Seat belt Interlocked swivel seat

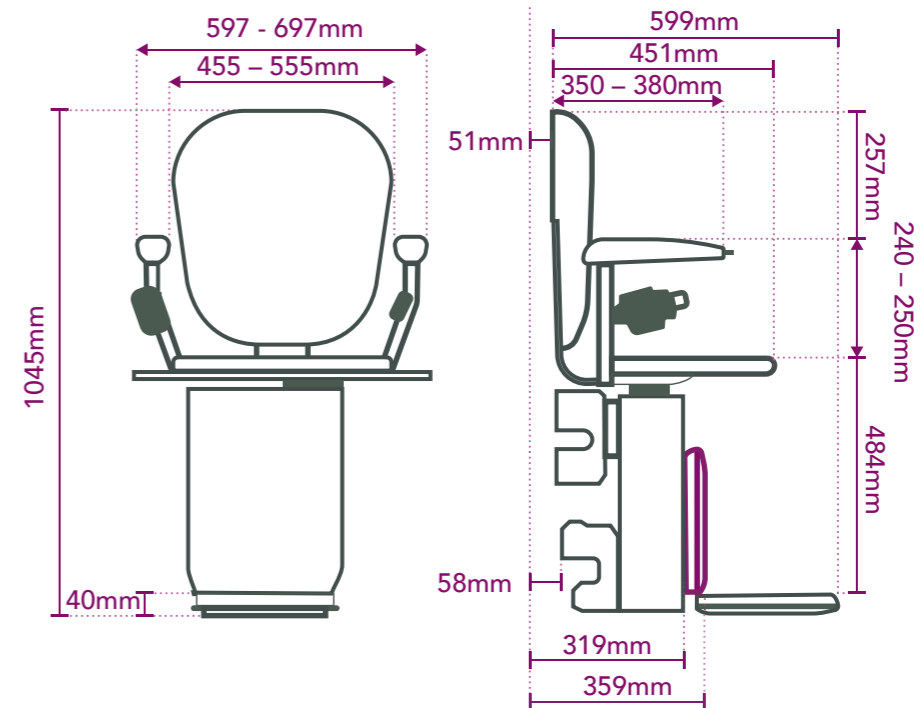
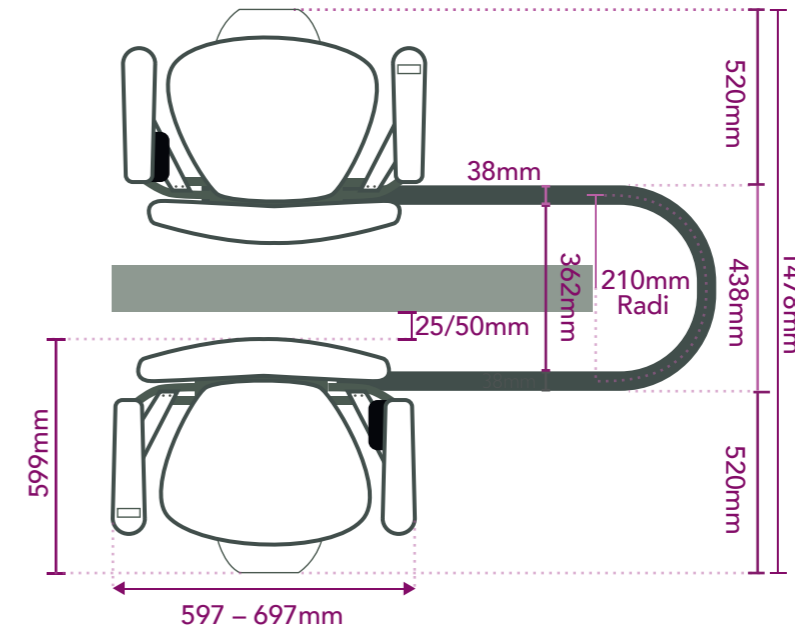



WHY CHOOSE PLATINUM?

Platinum Stairlifts are a British manufacturer, located in Yorkshire. We have been a provider of high quality stairlifts since 1996.

Committed to the highest level of quality, safety, comfort and reliability. Every stairlift is tested in our manufacturing facility to the highest standards prior to delivery and comes with a personalised signed certificate of quality.

Platinum Stairlifts works closely with an Approved Partner Network across the world. You can be assured that your stairlift provider is confident in our quality product and is fully trained and supported by us to provide the best solution for you.

“When our customers need a stairlift, time is of the essence. This is why we choose to work with Platinum Stairlifts – they provide a quality product for staircases of all shapes and sizes, and with a great turnaround time. Finally, if there are ever any issues, they are always on hand to support us and resolve things quickly.”

*Platinum Partner
March 2021*





Quality | Reliability | Partnership | Innovation | Caring



Certified to comply with BSEN81-40 :2008
For patent information, please visit www.platinumstairlifts.com/patent